



BELLE  
LIGHT  
CONSTRUCTION  
EQUIPMENT



# RPX 35

## REVERSIBLE PLATE COMPACTORS



BELLE  
LIGHT  
CONSTRUCTION  
EQUIPMENT

# RPX RANGE

**IF YOU'RE NOT MOVING FORWARDS  
YOU'RE MOVING BACKWARDS**

**NEW** heavy duty range of reversible plate compactors built to withstand the harshest site conditions. With improved baseplate design for excellent gradability & increased travel speeds and a higher compaction force for shorter usage times and deeper compaction.

Complete with integrated Wheel Kit for easy transportation these are the perfect solution for the rental market.

Available with Honda petrol, Hatz diesel or Hatz diesel electric engine options.

## **FEATURES & BENEFITS**

- Robust design for long-life and use in the harshest site conditions.
- Petrol & Diesel models to suit all kind of applications combining low weight with high compaction force.
- Electric start with key ignition & LED warning lamps, eliminates need for operator training with manual starting (Hatz models only)
- Integrated Wheel Kit, ready for safe and easy transporation.
- Control Handle & Additional Fixed Handle with strong locking:-
  - More positive handling & control.
  - Reduces shock loading on control handles.
  - Better fulcrum for pulling machine onto its wheels.
  - Safe for operator moving without relying on moving control handles.
  - No damage to the forward/reverse mechanism.
- Angled baseplate for excellent gradability and travel speeds.
- Low HAV handle, safe for operators to use for long periods.
- High Compaction force for fast work and deep compaction.
- Handle mounted throttle, perfect for the operator
- Compact, high performace, sealed for life Lithium Ion battery.  
Dry battery = no liquid acid
- Available with 40cm, 50cm or 60cm width baseplate.
- Specifically designed for hire and rental markets.
- Paving Pad option available.







**HANDLE MOUNTED THROTTLE, PERFECT FOR THE OPERATOR**



**CENTRALLY LOCATED RECOIL START / STOP BUTTON CONTROLS (PETROL MODEL)**



**ELECTRIC, KEY IGNITION START & LED WARNING LAMPS (DIESEL ELECTRIC MODEL)**



**INTEGRATED WHEEL KIT READY FOR SAFE OPERATION**



**FIXED HANDLE TO AID TRANSPORTATION ON ROUGH TERRAIN**

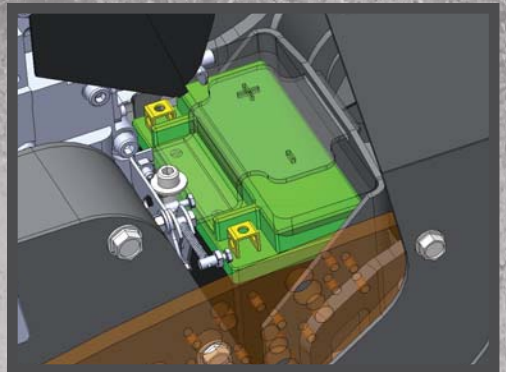

**COMPACT, HIGH-PERFORMANCE, SEALED FOR LIFE LITHIUM-ION BATTERY.  
DRY BATTERY = NO LIQUID ACID (DIESEL ELECTRIC MODEL)**

# TECHNICAL SPECIFICATIONS

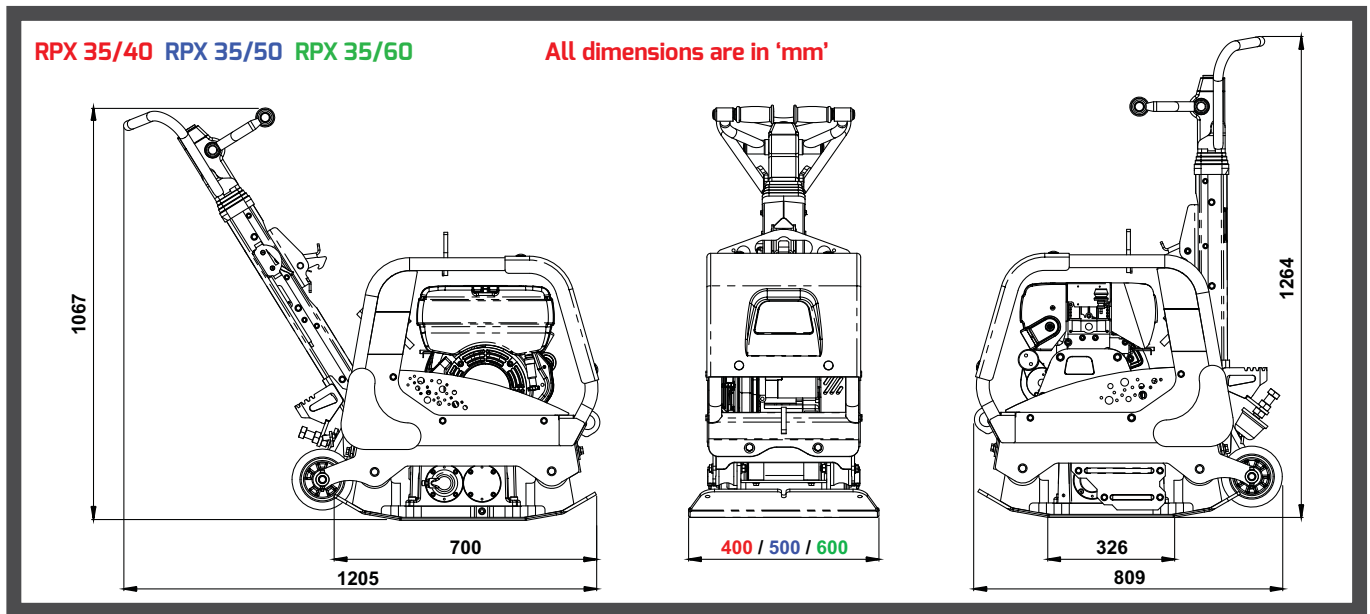

## RPX 35/40

Part No.	
Engine Power	(Hp / kW)
Engine RPM	
Static Pressure	(kg/m <sup>2</sup> )
Centrifugal Force	(kN)
Frequency	(Hz)
Max Gradient	(°)
Max. Travel Speed	(m/min)
Vibration Level	(m/sec <sup>2</sup> )
Weight	(kg)
Noise Level	(dB(A))

## Honda GX200 Petrol

161.9.202
5.5 / 4.0
3000
1351
35
81
20
27
3.1
176
108

## Hatz 1B20 Diesel

161.9.200
4.2 / 3.1
3000
1436
35
81
20
27
2.4
187
108

## Hatz 1B20 Diesel Electric Start

161.9.201
4.2 / 3.1
3000
1449
35
81
20
27
2.4
189
108

## RPX 35/50

Part No.	
Engine Power	(Hp / kW)
Engine RPM	
Static Pressure	(kg/m <sup>2</sup> )
Centrifugal Force	(kN)
Frequency	(Hz)
Max Gradient	(°)
Max. Travel Speed	(m/min)
Vibration Level	(m/sec <sup>2</sup> )
Weight	(kg)
Noise Level	(dB(A))

## Honda GX200 Petrol

161.9.205
5.5 / 4.0
3000
1104
35
81
20
26
3.1
180
108

## Hatz 1B20 Diesel

161.9.206
4.2 / 3.1
3000
1172
35
81
20
26
2.4
191
108

## Hatz 1B20 Diesel Electric Start

161.9.204
4.2 / 3.1
3000
190
35
81
20
26
2.4
194
108

## RPX 35/60

Part No.	
Engine Power	(Hp / kW)
Engine RPM	
Static Pressure	(kg/m <sup>2</sup> )
Centrifugal Force	(kN)
Frequency	(Hz)
Max Gradient	(°)
Max. Travel Speed	(m/min)
Vibration Level	(m/sec <sup>2</sup> )
Weight	(kg)
Noise Level	(dB(A))

## Honda GX200 Petrol

161.9.208
5.5 / 4.0
3000
944
35
81
20
25
3.1
185
108

## Hatz 1B20 Diesel

161.9.203
4.2 / 3.1
3000
1000
35
81
20
25
2.4
196
108

## Hatz 1B20 Diesel Electric Start

161.9.207
4.2 / 3.1
3000
1057
35
81
20
25
2.4
207
108



**BELLE**  
LIGHT  
CONSTRUCTION  
EQUIPMENT

ALTRAD BELLE  
Sheen, Nr. Buxton, Derbyshire, SK17 0EU, GB  
Tel. +44 (0)1298 84606 - Fax +44 (0)1298 84722 - Email: sales@altrad-belle.com  
[www.Altrad-Belle.com](http://www.Altrad-Belle.com)  
[www.ALTRAD-Belle247.com](http://www.ALTRAD-Belle247.com)